



POWERED SPEAKER

HS-P1500W (AS)

DESCRIPTION

The HS-P1500W AS is a 2-way self-powered speaker with a built-in digital amplifier and 15-inch woofer. The speaker's enclosure is made of resin. It can be installed and used in many different applications with combined use of the supplied accessories and/or the optional mounting brackets.

SPECIFICATIONS

Enclosure	Sealed type
Power Source	220 - 240 V AC (50/60Hz)
Rated Output	170W (Class D Amplifier)
Power Consumption	100W
Sensitivity	98 dB (1W, 1m)
Frequency Response	60Hz - 20kHz
Crossover Frequency	3 kHz
Directivity Angle	Horizontal: 90°, Vertical: 40°
Input	MIC/LINE : XLR-3-31 type combination connector (balanced/unbalanced, -60dB/0dB selective) AUX : XLR-3-31 type combination connector, -10dB unbalanced
Output	LINE out : XLR-3-31 type connector, 0dB unbalanced
Tone Control	Bass : ±10dB at 100Hz; Treble : ±10dB at 10kHz
Operating Temperature	-10°C to 40°C
Finish	Enclosure : Polypropylene, white ; Input panel : Surface-treated steel plate, white Punched net : Surface-treated steel plate, white
Dimension	451 (W) x 560 (H) x 400 (D) mm (17.76" X 22.04" X 15.75")
Weight	16kg (35.2 lb) unit only
Accessory	Power cord (2m)···1, Handle···1, Handle fitting bracket···2, Rubber foot···2, Screw M6 x 20···4.
Option	Mounting Bracket : HY-1500VW, HY-1500HW ; Ceiling mount bracket : HY-C0801 Wall mount bracket : HY-W0801 ; Speaker stand: ST-34B

APPEARANCE

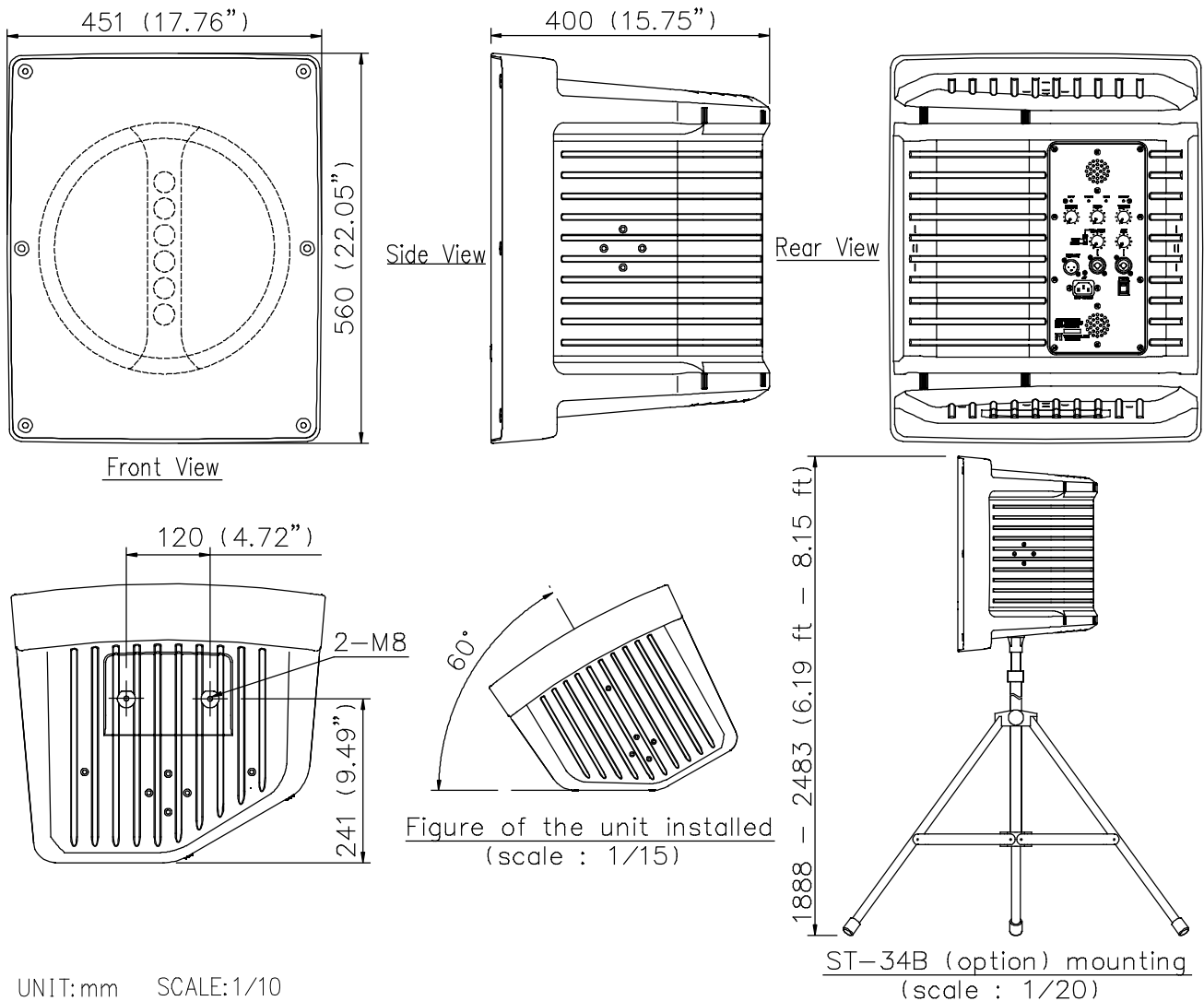

UNIT:mm SCALE:1/10